

GAS SAFETY EXCESS GAS FLOW AND LEAK DETECTION AUTOMATIC GAS SHUT-OFF SYSTEM

The Technik2 excess gas flow and leak detection system has been designed to save lives and property, aimed at the disabled, elderly, social housing and landlords.

This product is unique, due to remote wireless gas sniffing detectors, (which are fitted in each room that has a gas appliance.) There are systems on the market, that shut the gas supply off, if a major gas leak occurs. They look for a sudden pressure loss but if a cooker burner has gone out or been left on and the gas has not been ignited, the gas leak will build up to a dangerous level. The Technik2 system smells for gas 24hours a day and at the first sign of gas in a room, an audible alarm warns the occupant of a gas leak. If the gas leak is not stopped, a second danger limit is reached at 20% of the lower explosion limit and automatically it shuts the gas supply off at the meter. A warning text can also be sent to a warden or control centre.



MAINS POWER GAS DETECTORS

Direct mains powered hardwired gas detectors and up to 10 wireless gas sensors can be installed into each wireless receiver / gas valve.

On detecting a gas leak a loud 94 dB /0.3m alarm sounds and it safely and automatically shuts off the gas supply.

Once gas concentrations are safe and the source of the gas leak has been found and corrected, the gas safety valve can be reset to the open position by the manual reset button.



1" (DN25) GAS VALVE 230VAC COIL



WIRELESS RECEIVER

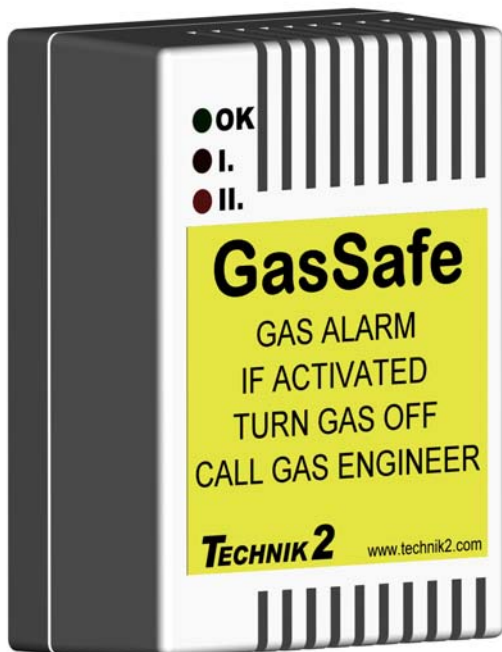

Gas detector
Mains or 12VDC powered



Remote receiver unit
12VDC powered



Remote receiver unit
Mains powered

Manual reset, normally open solenoid valve for gas.

M16 / RMO N.A

1. Description

This solenoid valve is a very simple and extremely safe. The coil, when under tension (manual reset) releases and closes the solenoid valve when the coil is activated. The solenoid valve has to be manually reset once activated. During normal conditions no electrical current is used, no heat is produced, no wear and tear and no buzzes or vibrations occur.

2. Installation

Please read the manufacturers instructions as supplied with each solenoid valve.

This valve **MUST BE INSTALLED AND TESTED BY A REGISTERED CORGI ENGINEER** and be installed in accordance with current legislation. Please bear in mind any possible pressure drops when installing any device into an existing system. If this solenoid valve is installed in the system to shut-off the gas supply to a device or property, a warning label should be attached to or near the gas meter to indicate "gas shut-off solenoid valve has been installed in the system". The solenoid valve should also be labelled "gas shut-off solenoid valve" The solenoid valve should be installed on the customer side of the gas meter as close to the meter as possible, the solenoid valve must be installed in the direction of the flow and markings on the solenoid valve. If the solenoid valve is to be installed in areas that suffer from sulphuric iron dust (black powder in the pipe work) please ensure the solenoid valve is fitted on the outlet side of the filter. Please check the coil operating voltage before applying power to the coil.

3. Testing

This solenoid valve should be tested annually in accordance with current legislation.

4. Servicing

Please read manufacturers instructions.

Ensure the electrical supply has been isolated and disconnected. Ensure there is no gas left in the solenoid valve or pipe work before doing any internal valve inspection.

5. Automatic gas systems options

This solenoid valve can be automatically operated if connected to gas leak detectors, remote switches, wireless receivers, 12VDC coils, battery back-up units, etc. Please contact your supplier for a list of system options.

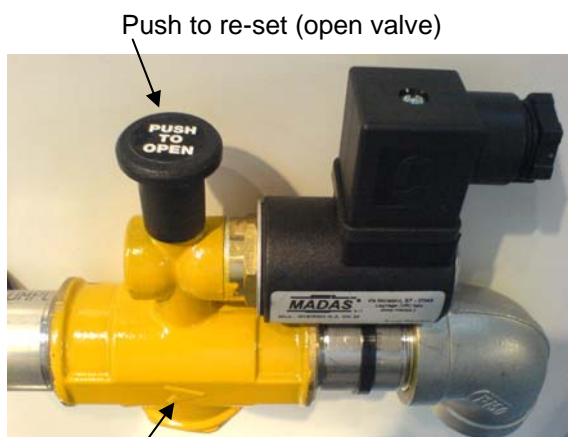

Push to re-set (open valve)

Gas flow direction
Marking on valve

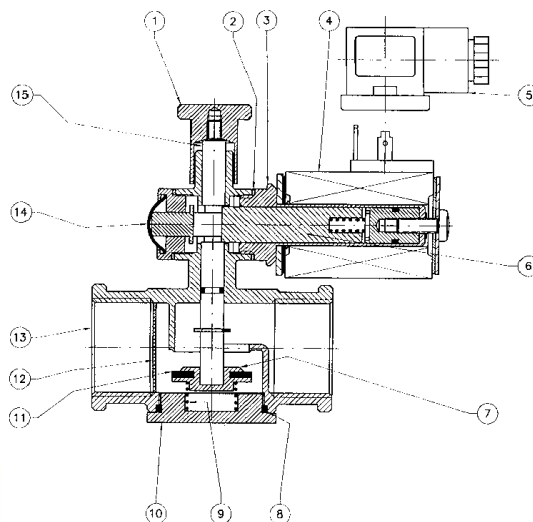
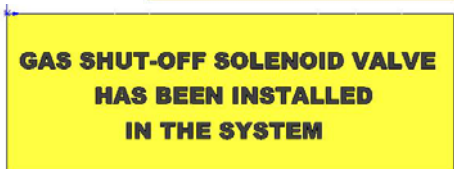
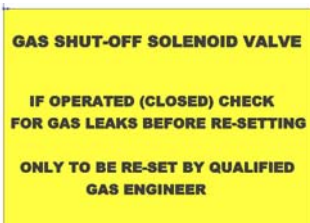

- 1 - Reset handgrip
- 2 - Aluminium washer
- 3 - Coil armature assembly
- 4 - Electrical coil
- 5 - Electrical connector
- 6 - Plunger
- 7 - Obturator
- 8 - Seal O-Ring
- 9 - Closing spring
- 10 - Lower cap
- 11 - Seal washer
- 12 - Filtering organ (on request)
- 13 - Body valve
- 14 - Closing manual push button (only on RO02C - RO03C - RO04C)
- 15 - Central pin

TECHNICAL DATA

- Use : not aggressive gases of the 3 families (dry gases)
- Threaded connections (brass body) : (DN 15 ÷ DN 25) according to ISO 7/1
- Environment temperature : -15 ÷ +60 °C
- Max. superficial temperature : 70 °C
- Power supply voltage : 12 V, 24 V, 110 V, 230 V
- Power absorption : see coils and connectors table
- Max. working pressure : 500 mbar
- Closing time : < 1 s
- Degree of protection : IP 65

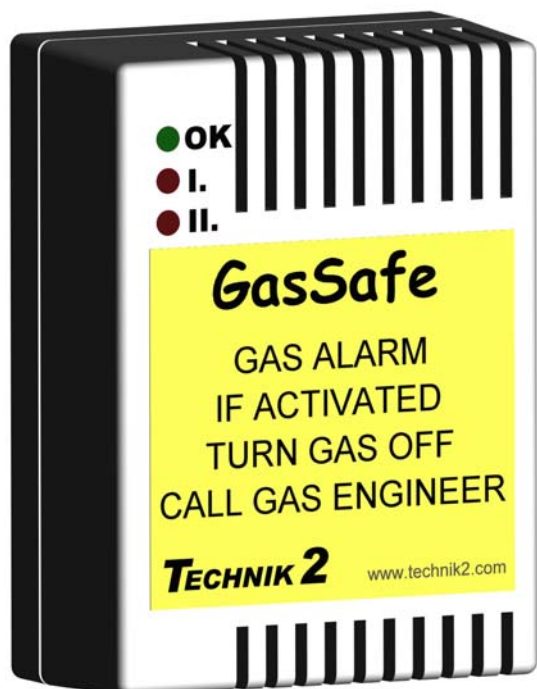

The Technik2 60G unit detects all mixtures of air and combustible gas (Natural Gas, Methane, Propane, Butane, Acetylene, GPL, Hydrogen, etc). The detector detects two levels of gas concentration, responding with two different output reactions.

The main detector features are: high reliability and sensitivity, compact size, 230V (110V 12VDC optional) power supply and long stability & lifetime. It has a built-in transmitter to wirelessly send an alarm signal.

SPECIFICATIONS

power supply	230V/50Hz (optionally 110V/60Hz), 5W
detection method	hot wire type
sensitivity of 1st level	10 % calibrated for methane
sensitivity of 2nd level	20% LEL calibrated for methane
buzzer sound level	94dB/0.3m
relay output	optional for 1st or 2nd level, max.230V/5A
alarm memory	selectable
response time	less than 10 sec
warm up time	30 sec
working range	max. 50m (open area)
working environment	indoor use -10 to +40°C, IP30
complies with	EN 60335-1



The Technik2 Receiver unit 222, is powered by 230 VAC with output relay contact rated at 6 Amp 250VAC. (fused)

There are four different operating modes available for each remote control.

SPECIFICATIONS

Operating voltage:	230 VAC, 50 Hz (110VAC optional)
Power consumption:	1.5 W
Operating frequency:	433.92 MHz
Coding:	digital, each remote control has an unique floating code
Output relay:	over switching dry contact fused 6A at 250 V
Range :(open area)	with RC-11 or RC-22 up to 30 metres with JA-60 items up to 100 metres

Description of system

This system has a remote shut-off switch wired in the supply line of the feed to the gas boiler. In the remote shut-off junction box there is a mains rated 10A / 240VAC latching relay. This relay has a 12VDC coil and is latched either ON or OFF via the outside control box. If the mains power is switched off and on, the latching relay will remain in its state.

To conduct a forced boiler shut-off. The gas engineer has a special key fob. He swipes it across the outside face of the outside control box. This action sends a signal to the latching relay, to turn the power supply to the gas boiler off. To re-set the relay, the engineer has to swipe the key fob across the face of the inside junction box. This will latch the relay to turn the power on.

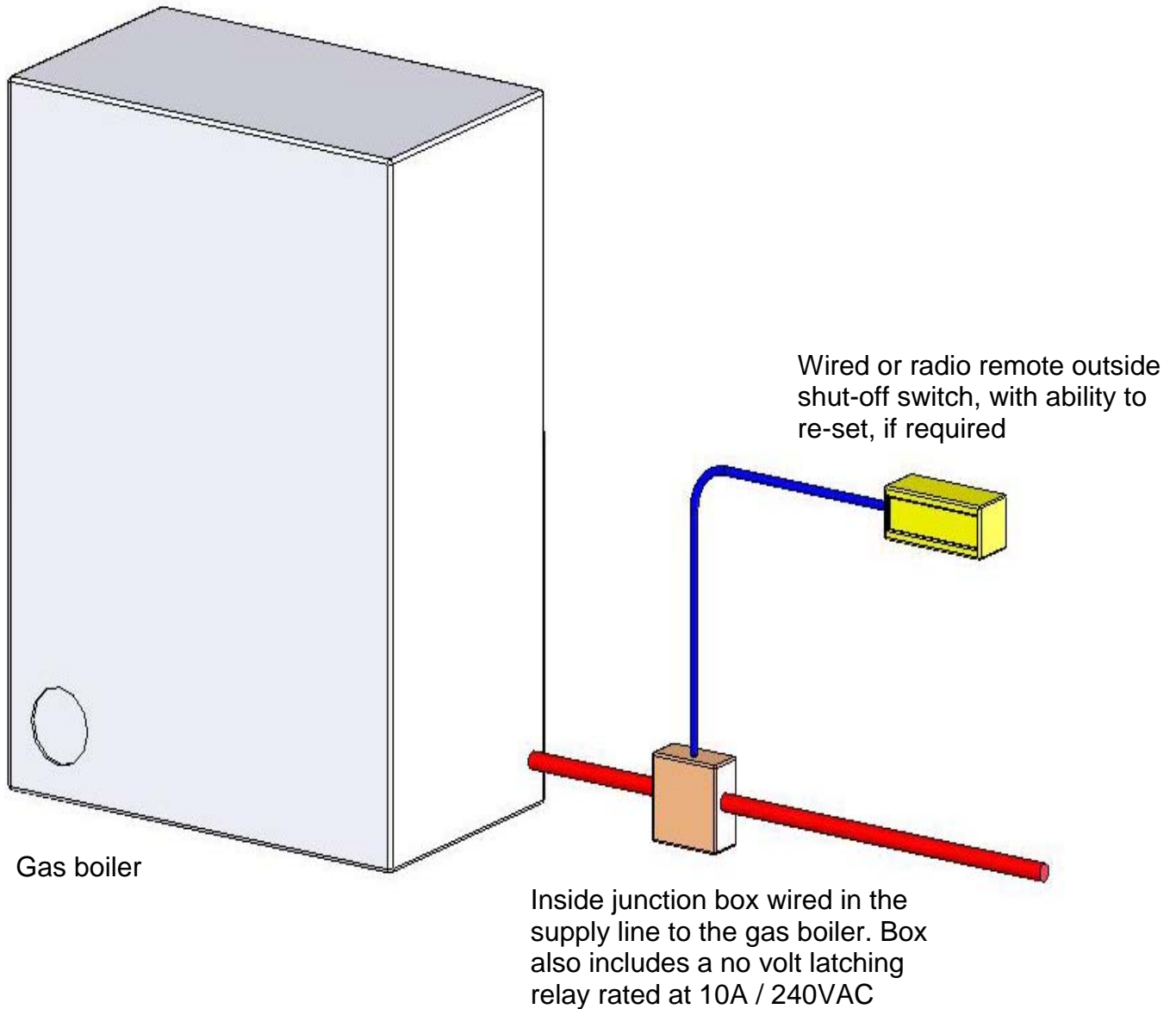

System shown would be powered by low voltage, 12VDC and could include a battery to give cover in power cuts, if required

Description of system

24 hour gas leak detection with audible alarm and automatic gas shut-off, including remote engineer forced gas shut-off facility.

To conduct a forced remote shut-off, the gas engineer or Council official swipes a special key tag across the externally mounted control box. This action sends a signal to the gas shut-off valve to close. To re-set, the engineer has to press the re-set button on the gas valve. The gas valve would be located within a locked box to avoid interference from unauthorised re-setting.

Benefits

The benefits of the Technik2 gas shut-off valve over automatic timed shut-off systems is:-

By having to visit the property by a Council official, the property may be vacant and or not suitable for the gas to be cut-off.

Automatic timed systems give NO allowance if the occupant is elderly, in hospital, disabled, with young children, etc.

The Technik2 system has the device to shut-off the gas on the outside of the building.

The Technik2 system gives 24 hour automatic protection against gas leaks or gas cookers left on with no flame.

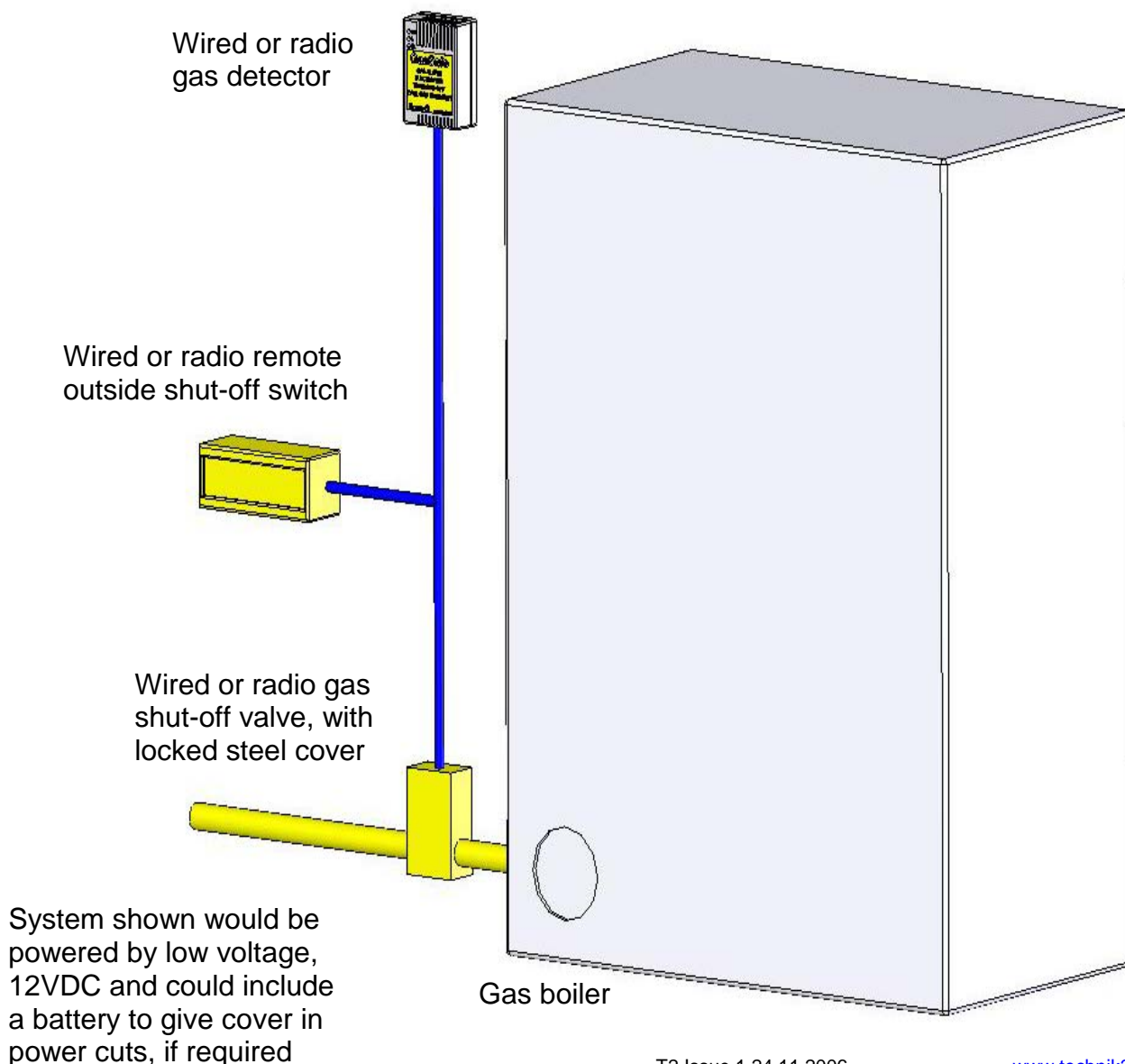

Automatic gas valve set-up installation instructions

This product is recommended for domestic natural gas use. With a minimum of one gas detector installed in rooms that a gas appliance may be used that is NOT fitted with an automatic flame failure control device, normally the kitchen. Other wireless gas detectors can be fitted to areas that may be a potential danger point for pockets of gas build up. Units MUST be installed by a qualified professional, the gas valve MUST be installed by a CORGI registered engineer.

It is recommended that you read the full instructions

It is possible to directly hardwire any number of gas detectors to the gas valve using the normally open relay contacts to send a signal to the gas valve to close. It is also possible to mix wireless gas detectors and hardwired units in the same system.

First you must ascertain the correct installation positions of each component. It is recommended that no more than 10 wireless gas detectors should be installed per activation receiver. The gas valve must be installed as close to the meter as possible on the customer side and in the direction of gas flow (see arrow on side on gas valve).

The distance between wireless gas detectors and activation receiver is critical. Radio waves act differently in each installation so keep unit distances to a minimum. As a rule the range (open air) is 25 metres.

Install the gas detectors first, in the best position to detect a gas leak. For natural gas it is recommended to be installed on a wall as close to the ceiling as possible (allowing for access to the top of the unit to remove the anti-tamper clip to remove the cover). Install units vertically as this gives greater radio range. The detector should not be located close to any obstacles preventing natural air circulation.

Install the wireless activation receiver as close to the wireless gas detectors as possible (install with the aerial vertical.) It's better to run a longer cable to the gas valve than decrease the radio range. Before fixing the receiver, it is recommended to test the wireless gas detectors range by following the enrolment instructions and test that each unit works. The red LED number 4 will flash and a click sound will be emitted from the receiver when a wireless gas detector sends a valid signal.

Enrolment instructions

Remove the outer cover from the activation receiver to expose the 1 to 4 red LED's and the programme button. Turn on the power to the unit, press the programme button once and the number 1 LED will flash for 10 seconds. Within this time you must turn on the power to the gas detector. All 1 to 4 LED's will flash once to confirm enrolment. For the next gas detector, press the programme button once and number 1 LED will flash for 10 seconds. Within this time turn power on to the second gas detector. All 1 to 4 LED's will flash once to confirm enrolment. Repeat for up to 10 wireless detectors.

On powering up the gas detector units, the green LED will flash to indicate unit warming up. Only when the Green LED is permanently on is the unit ready.

Maintenance instructions

System must be fully tested every 12 months.

Gas detector chamber should work properly at least for 5 years. The auto detect procedure tests the gas chamber to see if it has gone out of range. If out of range, the red LED II will flash. If linked to a master control panel, the panel will indicate the faulty gas chamber automatically.

Battery systems should have the batteries checked every 12 months and changed after 3 years use.

Servicing

See gas valve data sheet and manufacturers instructions.